



COLOR MONITOR

SERVICE MANUAL

CHASSIS NO. : CL-61

MODEL: FLATRON L1720B (L1720BM-AL**R)

CAUTION

BEFORE SERVICING THE UNIT,
READ THE **SAFETY PRECAUTIONS** IN THIS MANUAL.

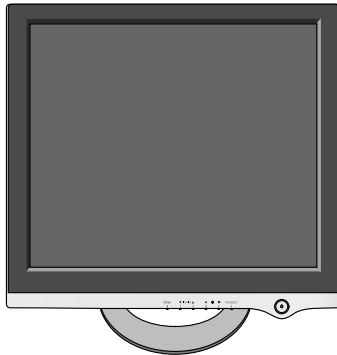

***Same looking with new chassis.**

CONTENTS

SPECIFICATIONS	2	ADJUSTMENT	10
PRECAUTIONS	3	TROUBLESHOOTING GUIDE	12
TIMING CHART	4	EXPLODED VIEW	16
OPERATING INSTRUCTIONS	5	REPLACEMENT PARTS LIST	18
WIRING DIAGRAM	6	PIN CONFIGURAION.....	20
BLOCK DIAGRAM	7	SCHEMATIC DIAGRAM.....	21
DESCRIPTION OF BLOCK DIAGRAM.....	8		

SPECIFICATIONS

1. LCD CHARACTERISTICS

Type : TFT SXGA LCD
 Size : 17 inch
 Pixel Pitch : 0.264 (H) x 0.264 (V)
 Color Depth : 16.2M colors
 Electrical Interface : LVDS
 Surface Treatment : Hard-coating(3H), Anti-Glare
 Operating Mode : Normally White, Transmissive mode
 Backlight Unit : Top/Bottom edge side 4-CCFL
 (Cold Cathode Fluorescent Lamp)

2. OPTICAL CHARACTERISTICS

2-1. Viewing Angle by Contrast Ratio ≥ 10
 Left : -60° min., -70°(Typ) Right : +60° min., +70°(Typ)
 Top : +45° min., +60°(Typ) Bottom : -45° min., -60°(Typ)

2-2. Luminance : 200(min), 250(Typ)

2-3. Contrast Ratio : 300(min), 450(Typ)

3. SIGNAL (Refer to the Timing Chart)

3-1. Sync Signal
 • Type : Separate Sync,
 SOG (Sync On Green)
 Composite Sync

3-2. Video Input Signal

1) Type : R, G, B Analog
 2) Voltage Level : 0~0.71 V
 a) Color 0, 0 : 0 Vp-p
 b) Color 7, 0 : 0.467 Vp-p
 c) Color 15, 0 : 0.714 Vp-p
 3) Input Impedance : 75 Ω

3-3. Operating Frequency

Horizontal : 30 ~ 83kHz
 Vertical : 56 ~ 75Hz

4. Max. Resolution

Analog : 1280 x 1024 / 75Hz

5. POWER SUPPLY

5-1. Power : AC 100-240V~, 50/60Hz , 1.0A

5-2. Power Consumption

MODE	H/V SYNC	VIDEO	POWER CONSUMPTION	LED COLOR
POWER ON (NORMAL)	ON/ON	ACTIVE	less than 43 W	BLUE
STAND-BY	OFF/ON	OFF	less than 1 W	AMBER
SUSPEND	ON/OFF	OFF	less than 1 W	AMBER
DPMS OFF	OFF/OFF	OFF	less than 1 W	AMBER

6. ENVIRONMENT

6-1. Operating Temperature: 10°C~35°C (50°F~95°F)
 (Ambient)
 6-2. Relative Humidity : 10%~80%
 (Non-condensing)
 6-3. MTBF : 50,000 Hours(Min)

7. DIMENSIONS (with TILT/SWIVEL)

FullUp Position

Width : 394 mm (15.51")
 Depth : 232 mm (9.13")
 Height : 379 mm (14.92")



Folded Position

Width : 394mm (15.51")
 Depth : 127mm (9.13")
 Height : 412mm (14.92")



8. WEIGHT (with TILT/SWIVEL)

Net. Weight : 4.5 kg (9.92 lbs)
 Gross Weight : 7.6 kg (16.76 lbs)

PRECAUTION

WARNING FOR THE SAFETY-RELATED COMPONENT.

- There are some special components used in LCD monitor that are important for safety. **These parts are marked  on the schematic diagram and the replacement parts list.** It is essential that these critical parts should be replaced with the manufacturer's specified parts to prevent electric shock, fire or other hazard.
- Do not modify original design without obtaining written permission from manufacturer or you will void the original parts and labor guarantee.

TAKE CARE DURING HANDLING THE LCD MODULE WITH BACKLIGHT UNIT.

- Must mount the module using mounting holes arranged in four corners.
- Do not press on the panel, edge of the frame strongly or electric shock as this will result in damage to the screen.
- Do not scratch or press on the panel with any sharp objects, such as pencil or pen as this may result in damage to the panel.
- Protect the module from the ESD as it may damage the electronic circuit (C-MOS).
- Make certain that treatment person's body are grounded through wrist band.
- Do not leave the module in high temperature and in areas of high humidity for a long time.
- The module not be exposed to the direct sunlight.
- Avoid contact with water as it may a short circuit within the module.
- If the surface of panel become dirty, please wipe it off with a softmaterial. (Cleaning with a dirty or rough cloth may damage the panel.)

WARNING

BE CAREFUL ELECTRIC SHOCK !

- If you want to replace with the new backlight (CCFL) or inverter circuit, must disconnect the AC adapter because high voltage appears at inverter circuit about 650Vrms.
- Handle with care wires or connectors of the inverter circuit. If the wires are pressed cause short and may burn or take fire.

CAUTION

Please use only a plastic screwdriver to protect yourself from shock hazard during service operation.

TIMING CHART

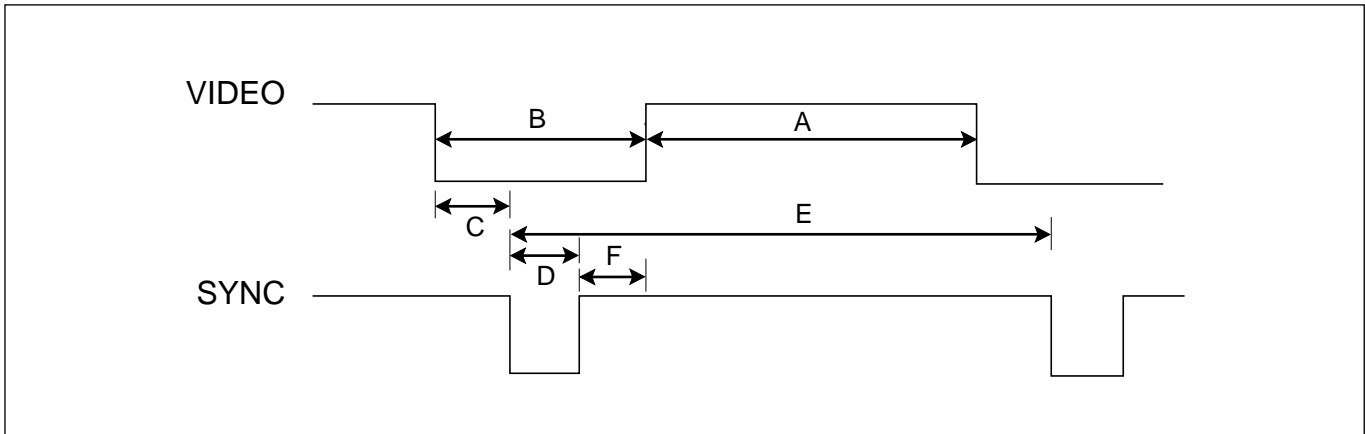

<< Dot Clock (MHz), Horizontal Frequency (kHz), Vertical Frequency (Hz), Horizontal etc... (μs), Vertical etc... (ms) >>

Mode	H/V Sort	Sync Polarity	Dot Clock	Frequency	Total Period (E)	Video Active Time (A)	Front Porch (C)	Sync Duration (D)	Back Porch (F)	Resolution
1	H	+	25.175	31.469	800	640	16	96	48	640x350 70Hz
	V	-		70.8Hz	449	350	37	2	60	
2	H	-	28.321	31.468	900	720	18	108	54	720x400 70Hz
	V	+		70.09	449	400	12	2	35	
3	H	-	25.175	31.469	840	640	16	96	48	640x480 60Hz
	V	-		59.94	525	480	10	2	33	
4	H	-	31.5	37.5	840	640	16	64	120	640x480 75Hz
	V	-		75	500	480	1	3	16	
5	H	+	40.0	37.879	1056	800	40	128	88	800x600 60Hz
	V	+		60.317	628	600	1	4	23	
6	H	+	49.5	46.875	1056	800	16	80	160	800x600 75Hz
	V	+		75.0	625	600	1	3	21	
7	H	+/-	57.283	49.725	1152	832	32	64	224	832x624 75Hz
	V	+/-		74.55	667	624	1	3	39	
8	H	-	65.0	48.363	1344	1024	24	136	160	1024x768 60Hz
	V	-		60.0	806	768	3	6	29	
9	H	-	78.75	60.123	1312	1024	16	96	176	1024x768 75Hz
	V	-		75.029	800	768	1	3	28	
10	H	+/-	100.0	68.681	1456	1152	32	128	144	1152x870 75Hz
	V	+/-		75.062	915	870	3	3	39	
11	H	+/-	92.978	61.805	1504	1152	18	134	200	1152x900 65Hz
	V	+/-		65.96	937	900	2	4	31	
12	H	+	108.0	63.981	1688	1280	48	112	248	1280x1024 60Hz
	V	+		60.02	1066	1024	1	3	38	
13	H	+	135.0	79.976	1688	1280	16	144	248	1280x1024 75Hz
	V	+		75.035	1066	1024	1	3	38	

OPERATING INSTRUCTIONS

FRONT VIEW

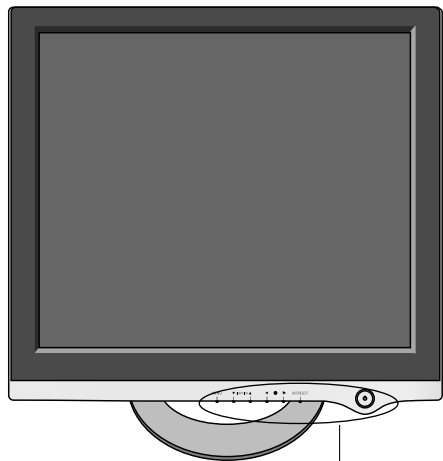

See front control panel

REAR VIEW

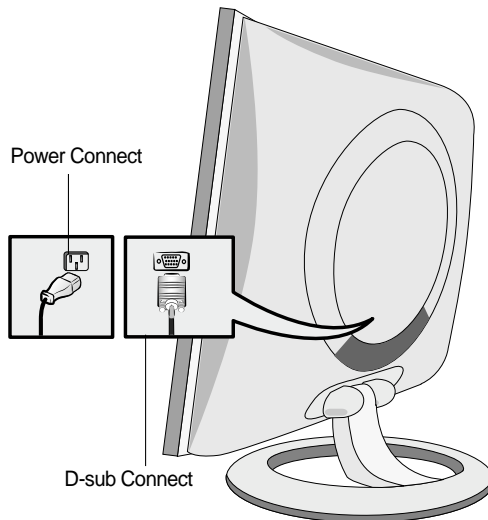

Power Connect

D-sub Connect

Front Control Panel

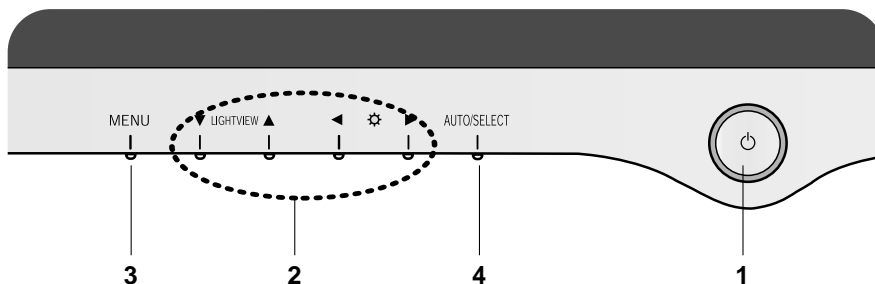

1. Power Button

Use this button to turn the display on or off.

<Power (DPMS) Indicator>

This Indicator lights up blue when the display operates normally. If the display is in DPM (Energy Saving) mode, this indicator color changes to amber.

2. ▲▼/◀▶ Button

Use these buttons to choose or adjust items in the On Screen Display.

▼ LightView ▲

This feature lets you easily select the best desired image condition optimized to the environment (ambient illumination, image types etc.).

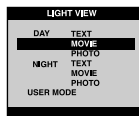

- **DAY** : Bright ambient illumination
- **NIGHT** : Dark ambient illumination
- **TEXT** : For text images (Word processing etc.)
- **MOVIE** : For animation images in videos or movies
- **PHOTO** : For pictures or drawings
- **USER MODE** : For use under user setup image conditions (Brightness, contrast and color tint are selected by the user in OSD Screen Setup Menu.)

▼ LightView ▲ → ▼ LightView ▲ → MENU

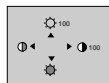

Bring up Contrast and Brightness adjustment.

: ◀ ⚙ ▶ → ▼ ▲ ▶ → MENU

3. Menu Button

Use this button to enter or exit the On Screen Display.

4. AUTO/SELECT Button

Use this button to enter a selection in the On Screen Display.



When adjusting your display settings, always press the **AUTO/SELECT** button before entering the On Screen Display(OSD). This will automatically adjust your display image to the ideal settings for the current screen resolution size (display mode).

The best display mode is **1024x768/60Hz**.

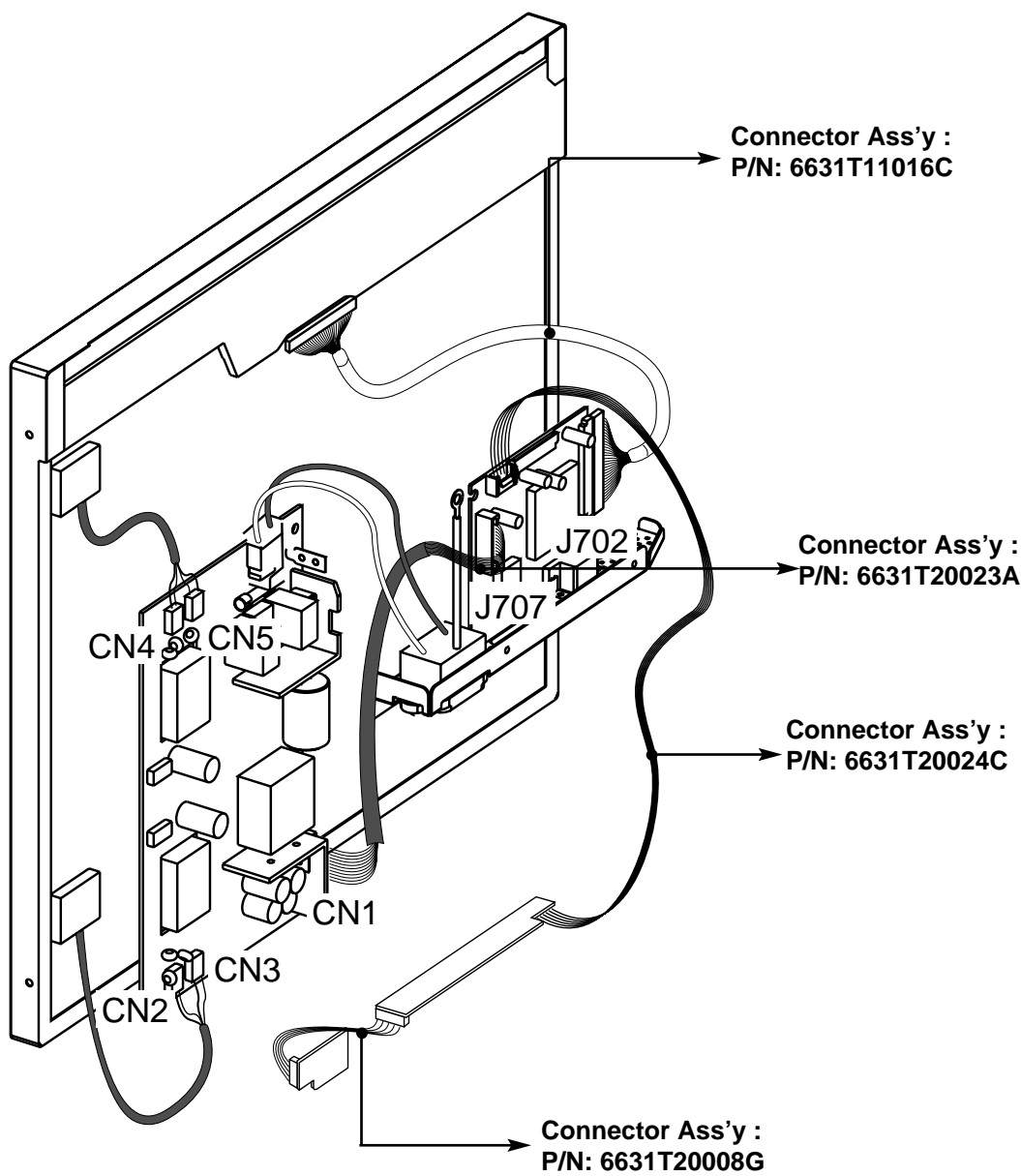

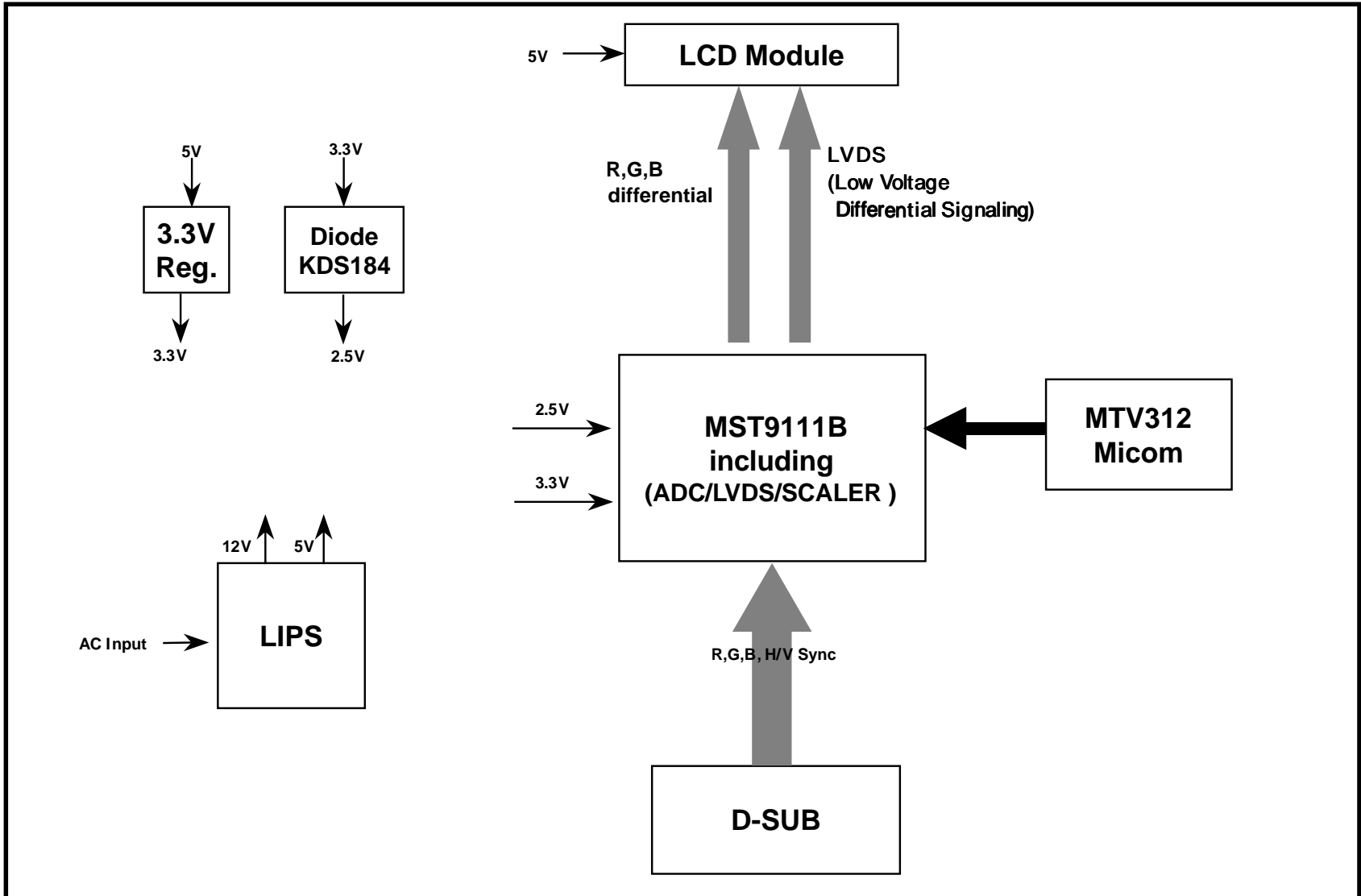

DESCRIPTION OF BLOCK DIAGRAM

1. Video Controller Part.

This part amplifies the level of video signal for the digital conversion and converts from the analog video signal to the digital video signal using a pixel clock.

The pixel clock for each mode is generated by the PLL.

The range of the pixel clock is from 25MHz to 135MHz.

This part consists of the Scaler, ADC, LVDS transmitter.

The Scaler gets the video signal converted analog to digital, interpolates input to 1280 X 1024 resolution signal and outputs 8-bit R, G, B signal to transmitter.

2. Power Part.

This part consists of the one 3.3V regulator, and two 2.5V drop diodes to convert power which is provided 12V, 5V in Power board.

5V is provided for LCD panel and Micom.

Also, 5V is converted 3.3V by regulator and 3.3V is converted 2.5V by drop diode.

Converted power is provided for IC in the main board.

3. MICOM Part.

This part consists of EEPROM IC which stores control data, Reset IC and the Micom.

The Micom distinguishes polarity and frequency of the H/V sync are supplied from signal cable.

The controlled data of each modes is stored in EEPROM.

LIPS Board Block Diagram

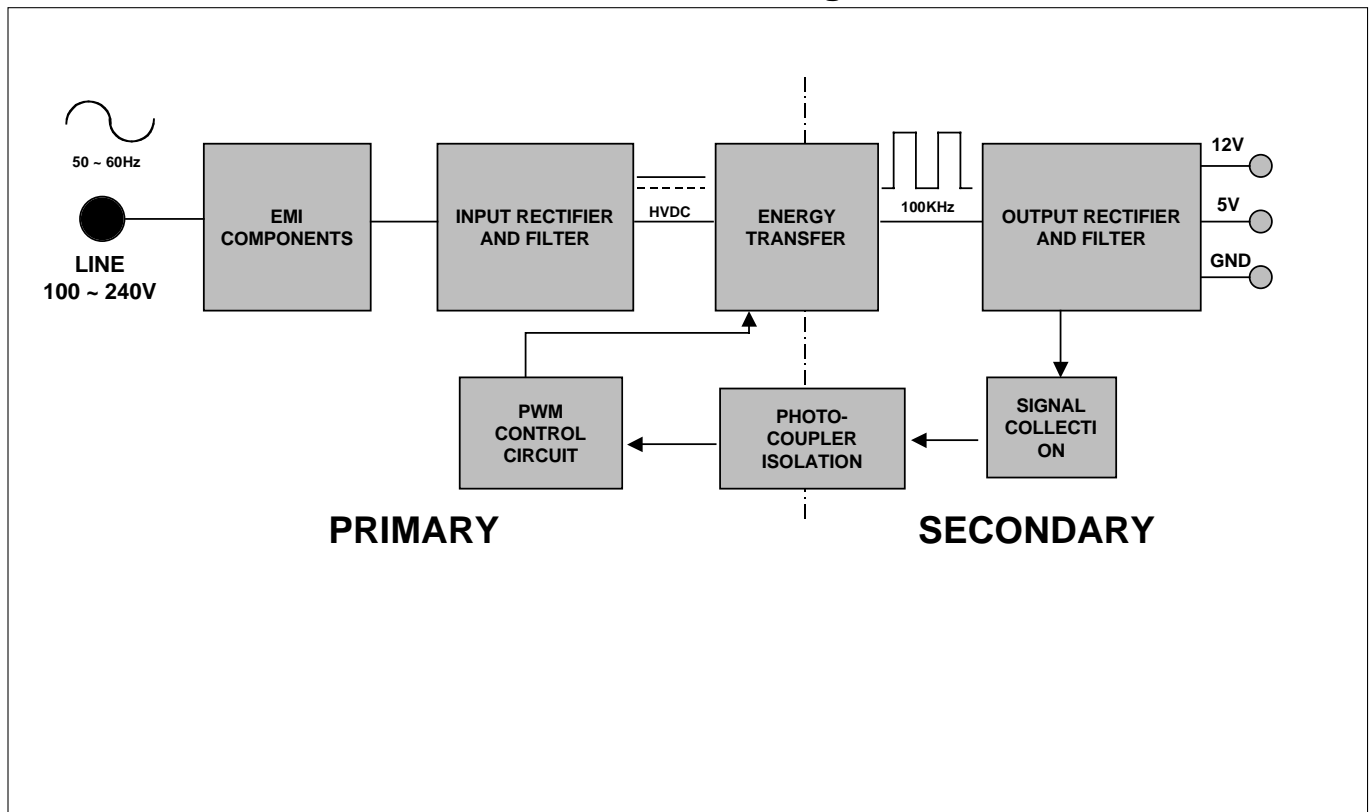

Operation description_LIPS

1. EMI components.

This part contains of EMI components to comply with global marketing EMI standards like FCC, VCCI CISPR, the circuit included a line-filter, across line capacitor and of course the primary protection fuse.

2. Input rectifier and filter.

This part function is for transfer the input AC voltage to a DC voltage through a bridge rectifier and a bulk capacitor.

3. Energy Transfer.

This part function is transfer the primary energy to secondary through a power transformer.

4. Output rectifier and filter.

This part function is to make a pulse width modulation control and to provide the driver signal to power switch, to adjust the duty cycle during different AC input and output loading condition to achive the dc output stablize, and also the over power protection is also monitor by this part.

5. Photo-Coupler isolation.

This part function is to feed back the dc output changing status through a photo transistor to primary controller to achieve the stabilized dc output voltage.

6. Signal collection.

This part function is to collect the any change from the dc output and feed back to the primary through photo transistor.

ADJUSTMENT

Windows EDID V1.0 User Manual

Operating System: MS Windows 98, 2000, XP

Port Setup: Windows 98 => Don't need setup

Windows 2000, XP => Need to Port Setup.

This program is available to LCD Monitor only.

1. Port Setup

- Copy "UserPort.sys" file to "c:\WINNT\system32\drivers" folder
- Run Userport.exe

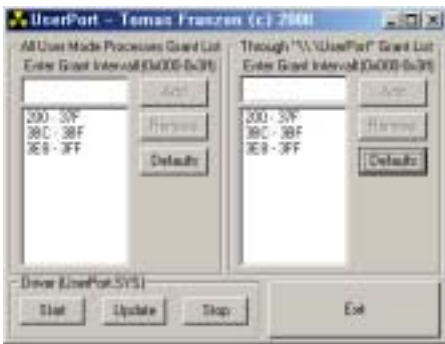

- Remove all default number
- Add 300-3FF

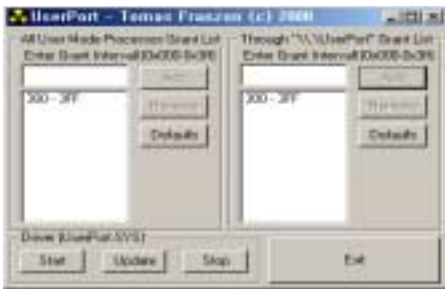

- Click Start button.
- Click Exit button.

2. EDID Read & Write

- Run WinEDID.exe



- 2) Edit Week of Manufacture, Year of Manufacture, Serial Number

- Input User Info Data
- Click "Update" button
- Click "Write" button

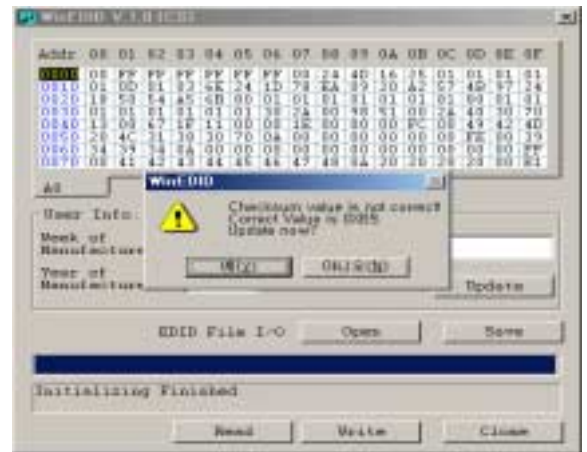

SERVICE OSD

- 1) Turn off the power switch at the front side of the display.
- 2) Wait for about 3 seconds and press MENU, POWER switch with 1 second interval.
- 3) The SVC OSD menu contains additional menus that the User OSD menu as described below.
 - a) MODULE : To select applied module.
 - b) NVRAM INIT : EEPROM initialize(24C08)
 - c) ADC OFFSET : The lowest value of input levels sets to digitally 0(zero).
 - d) ADC GAIN : The highest value of input levels sets to digitally 255.
 - e) ADC CAL : W/B balance sets the gain and offset value.
 - f) ELAPSED CLEAR : To initialize using time.

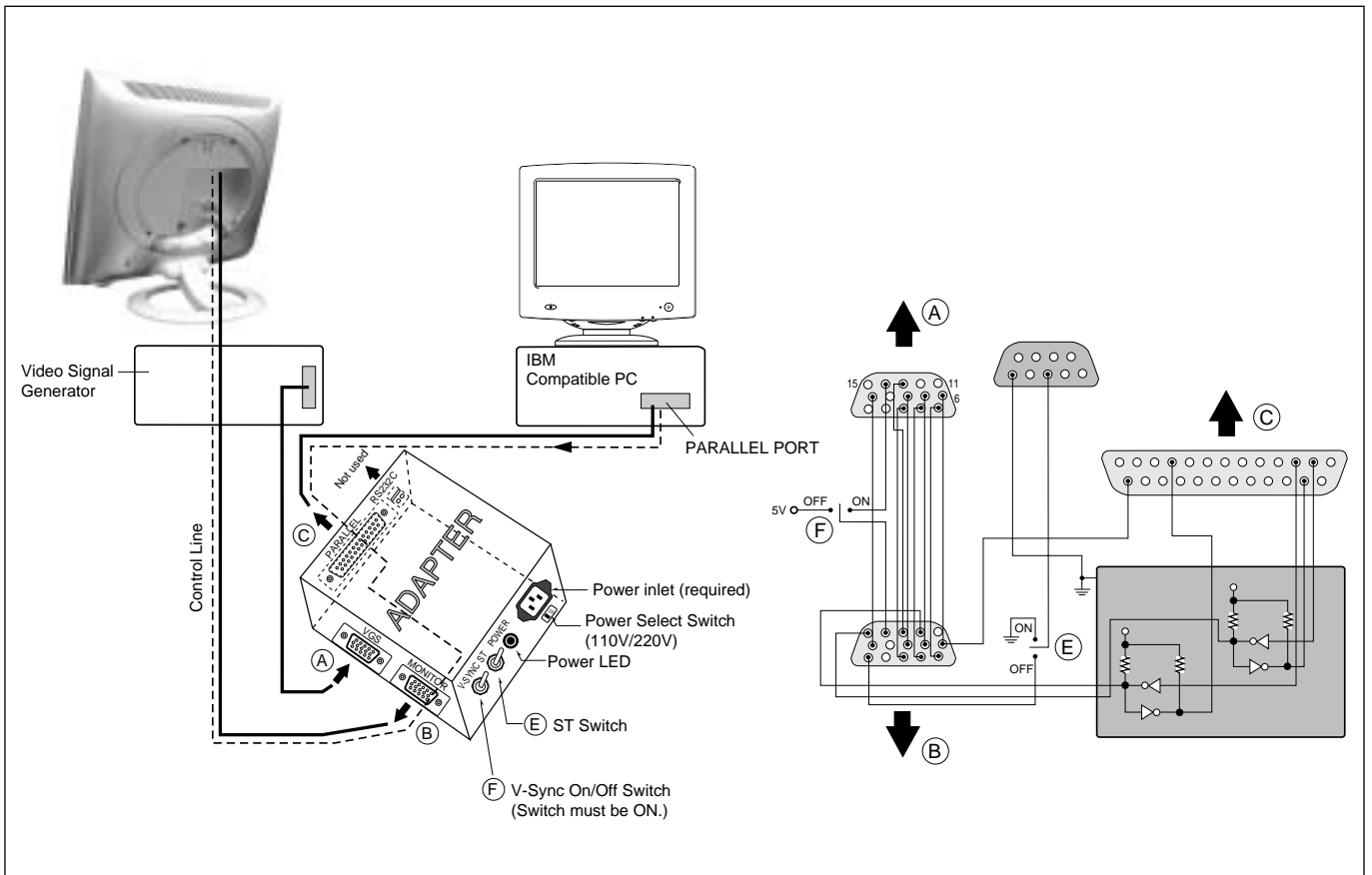
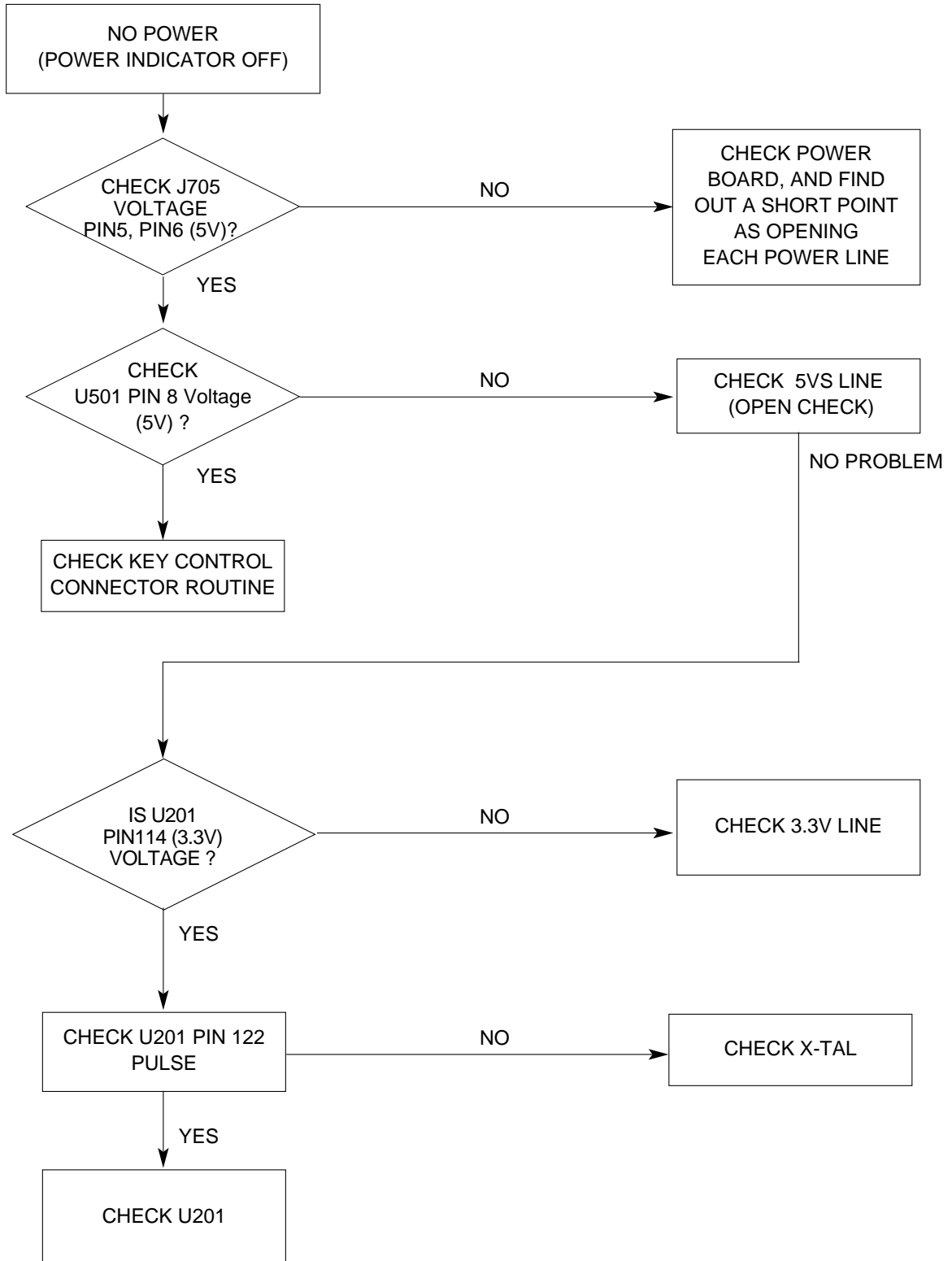

Figure 1. Cable Connection

TROUBLESHOOTING GUIDE

1. NO POWER



2. NO RASTER (OSD IS NOT DISPLAYED) – LIPS

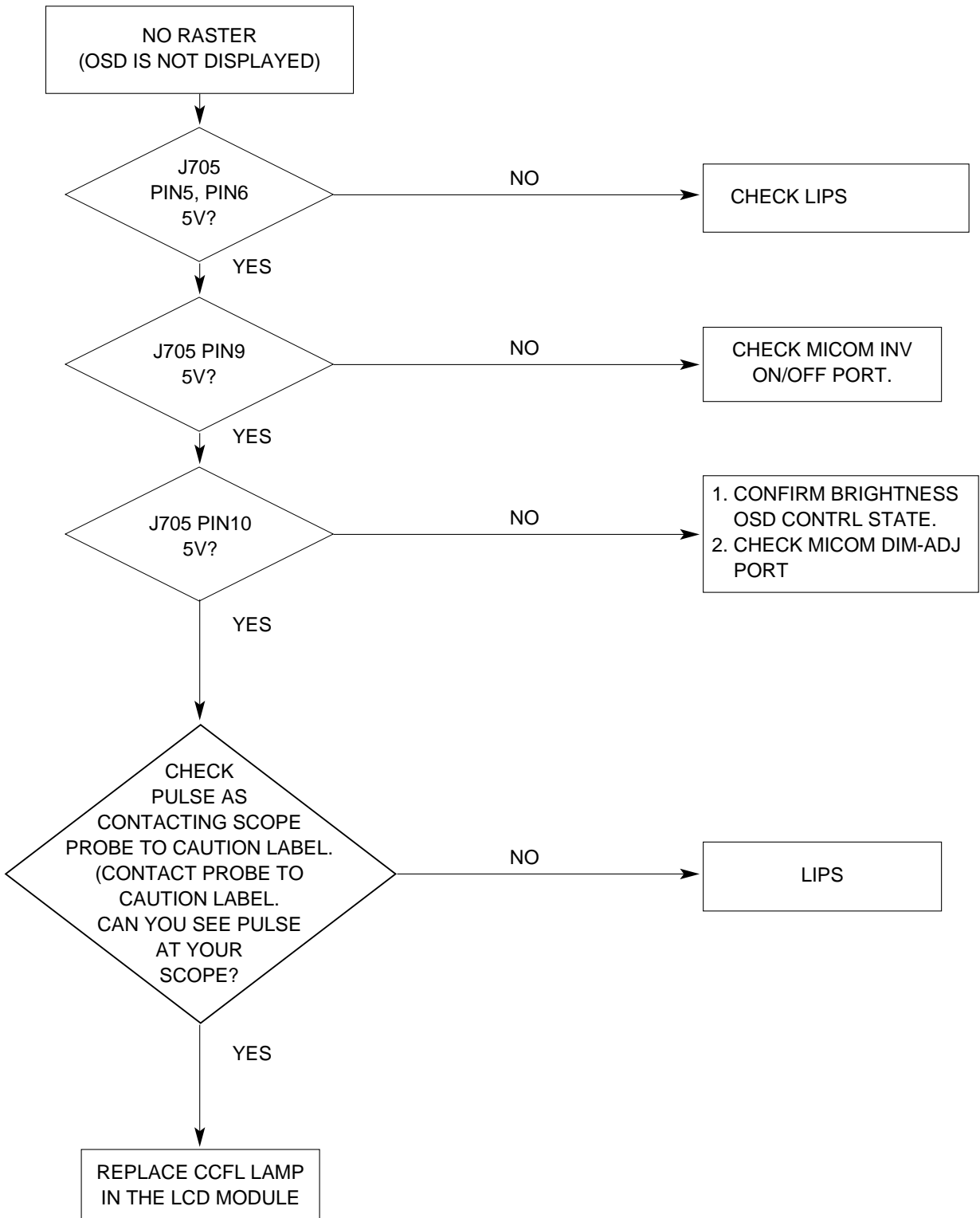

3. NO RASTER (OSD IS NOT DISPLAYED) – MST9111B

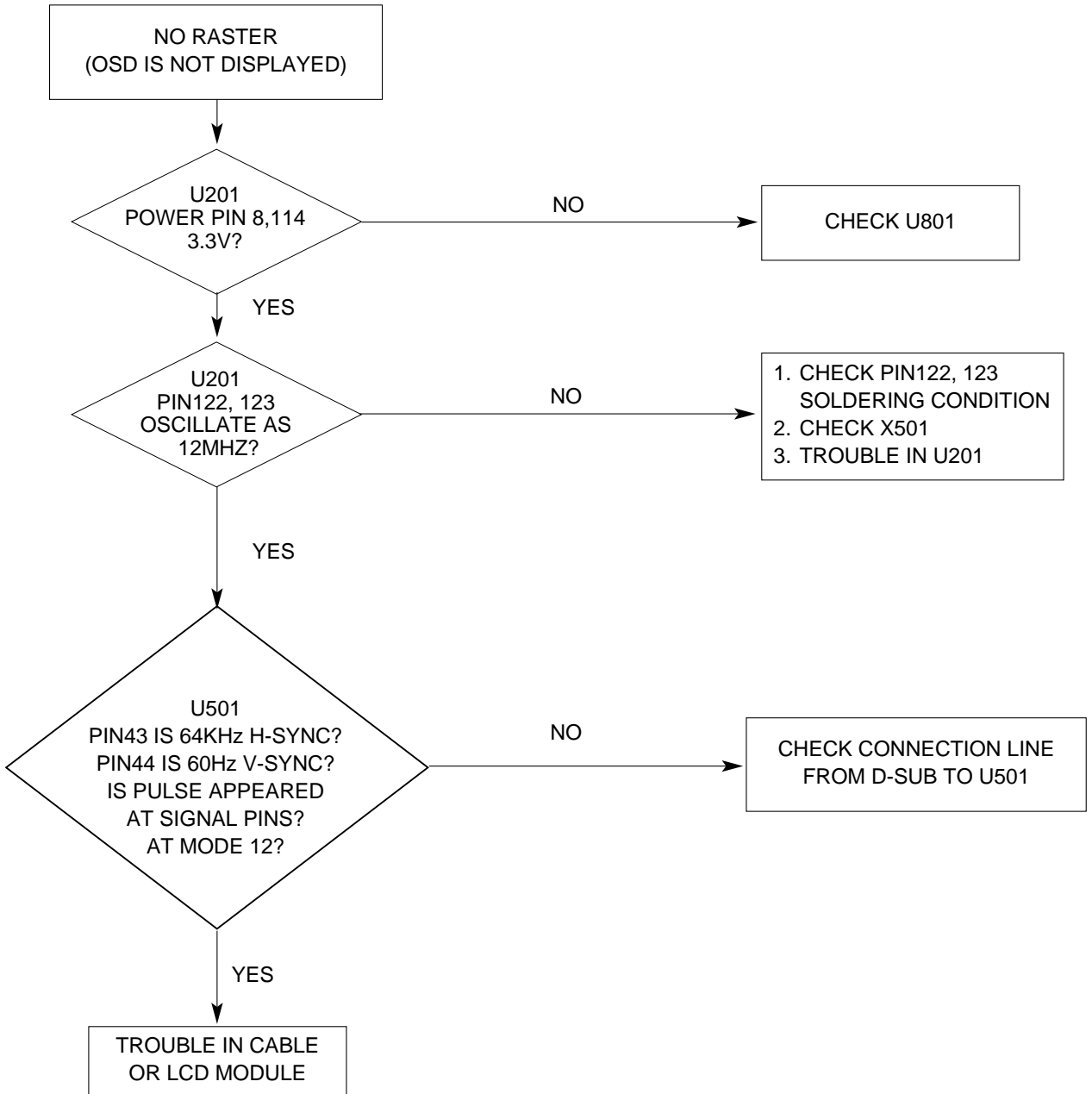

4. TROUBLE IN DPM

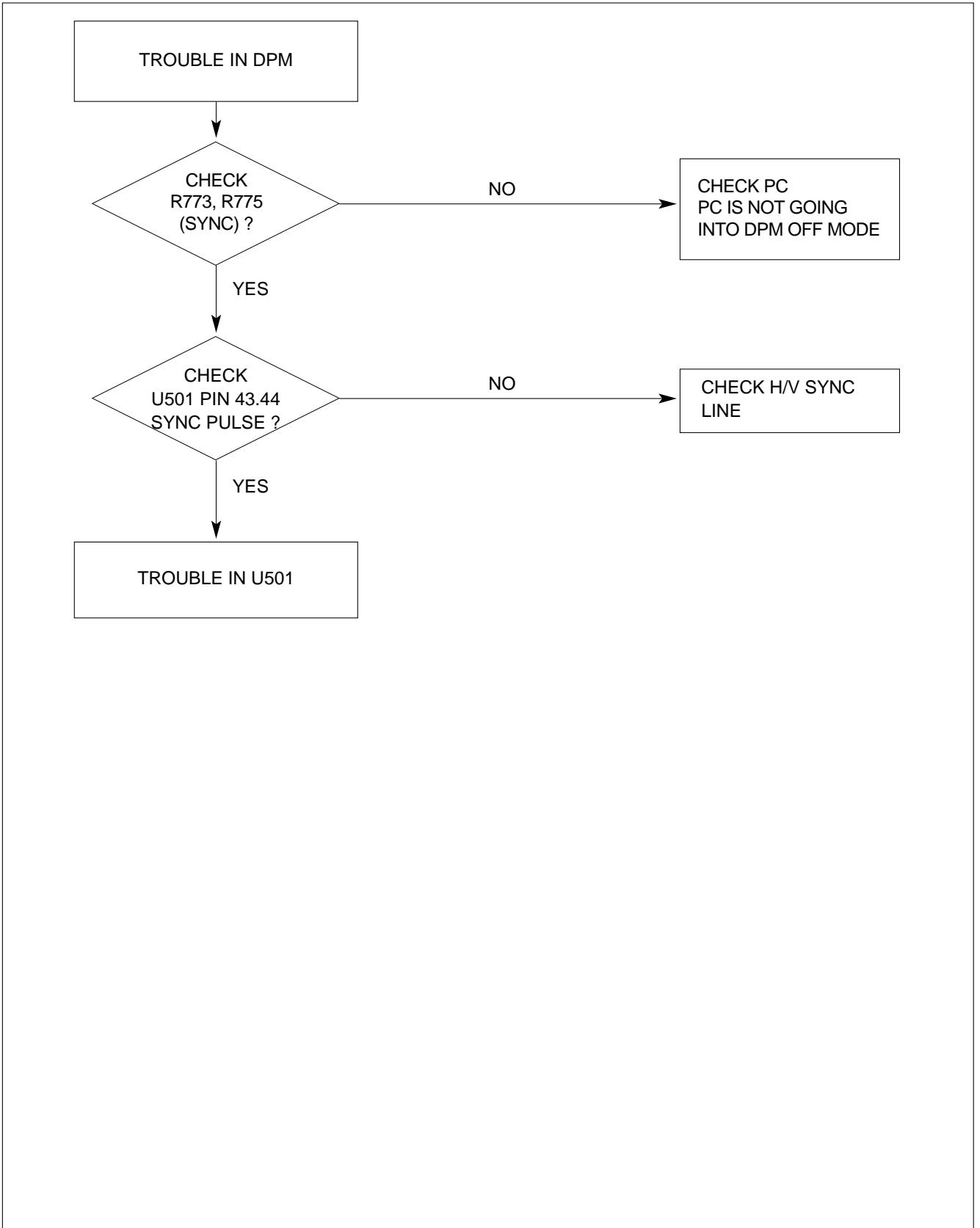

EXPLODED VIEW

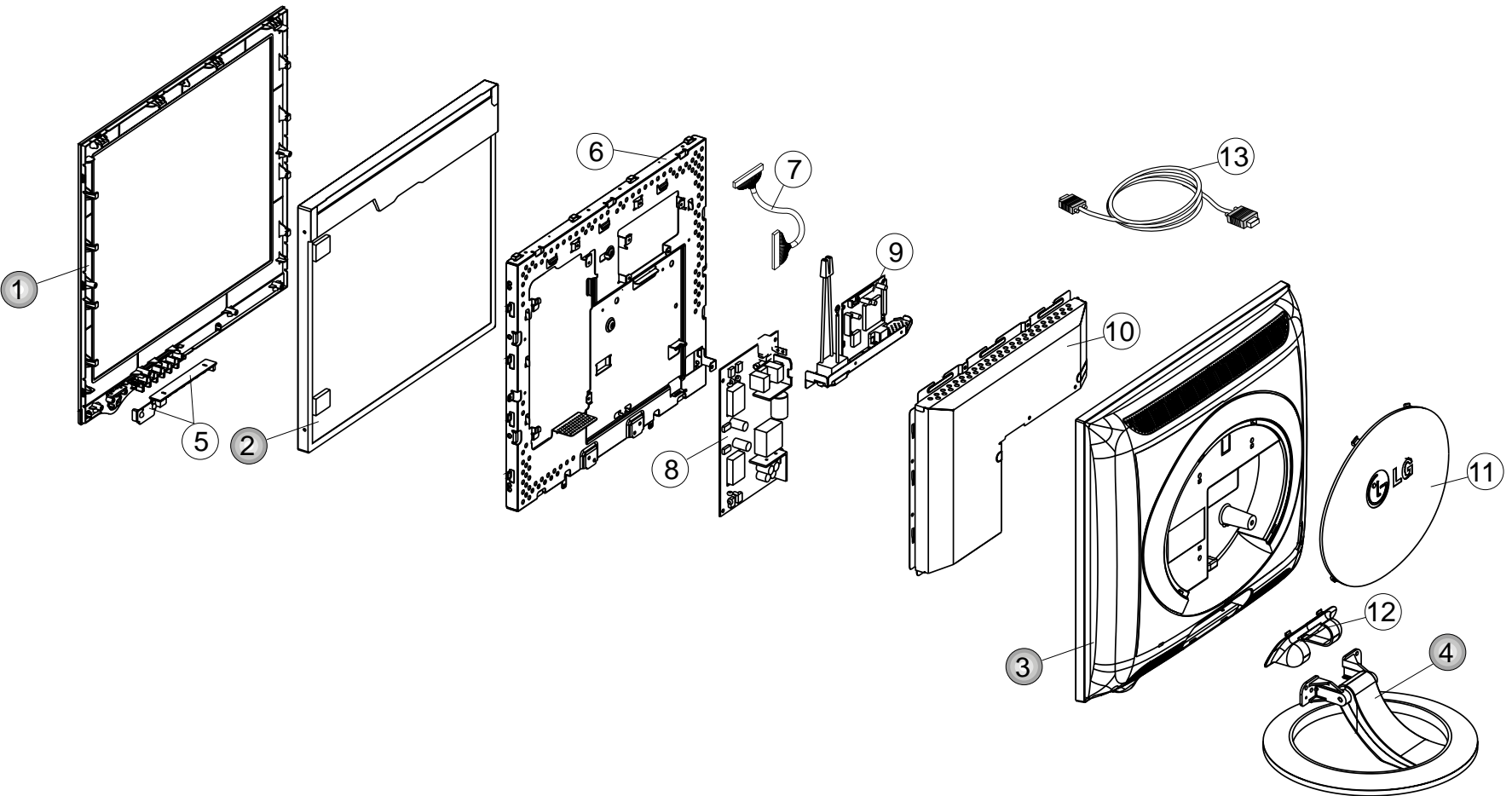

EXPLODED VIEW PARTS LIST

Ref. No.	Part No.	Description
1	3091TKL086A	CABINET ASSEMBLY, L1720 BRAND . .
2	6304FLP086A	LCD(LIQUID CRYSTAL DISPLAY), LM170E01-A5K6 LG PHILPS TFT COLOR LVDS SXGA OKI GATE D-IC
	6304FLP085A	LCD(LIQUID CRYSTAL DISPLAY), LM170E01-A4K4 LG PHILPS TFT COLOR SXGA LVDS OKI GATE D-IC
	6304FLP082A	LCD(LIQUID CRYSTAL DISPLAY), LM170E01-A5M1 LG PHILPS TFT COLOR SXGA LVDS PEM-NUT
	6304FLP076A	LCD(LIQUID CRYSTAL DISPLAY), LM170E01-A5 LG PHILPS TFT COLOR LVDS SXGA
	6304FLP058A	LCD(LIQUID CRYSTAL DISPLAY), LM170E01-A4 LG PHILPS TFT COLOR 17" TFT LCD
3	3809TKL059A	BACK COVER ASSEMBLY, L1720 . SILVER SPRAY
4	3043TKK134E	TILT SWIVEL ASSEMBLY , L1720B/PL M/BASE-SPRAY_NEW SCREW/RUBBER
5	6871TST430A	PWB(PCB) ASSEMBLY,SUB, L1720BL CONTROL TOTAL BRAND CL-43
6	4951TKS111E	METAL ASSEMBLY, FRAME MAIN L1720BM LPL
7	6631T11012W	CONNECTOR ASSEMBLY, 30P H-H 200MM UL20276 LG708G
8	6871TPT271C	PWB(PCB) ASSEMBLY, POWER, 19"+17" M-CHASSIS POWER TOTAL LIEN CHANG "INTEGRATED LIPS" FOR DOCKING TYPE
9	3313TL7038A	MAIN TOTAL ASSEMBLY, L1720BM BRAND CL-61
10	4951TKK139A	METAL ASSEMBLY, REAR L1720BL
11	3550TKK398A	COVER, L1720 BACK CAP
12	3550TKK400A	COVER, L1720BL HINGE CAP
13	6850TD9004M	CABLE, D-SUB, UL2990-9C(5.8MM) DT 1500MM GRAY 20 MODEL DM

DATE: 2003. 1. 9.				
*S	*AL	LOC. NO.	PART NO.	DESCRIPTION / SPECIFICATION
		R209	0RJ0682D677	68 OHM 1/10 W 5% 1608 R/TP
		R210	0RJ0682D677	68 OHM 1/10 W 5% 1608 R/TP
		R213	0RJ0000D677	0 OHM 1/10 W 5% 1608 R/TP
		R214	0RJ0000D677	0 OHM 1/10 W 5% 1608 R/TP
		R220	0RJ4701D677	4.7K OHM 1/10 W 5% 1608 R/TP
		R240	0RJ1001D677	1K OHM 1/10 W 5% 1608 R/TP
		R506	0RJ4701D677	4.7K OHM 1/10 W 5% 1608 R/TP
		R508	0RJ4701D677	4.7K OHM 1/10 W 5% 1608 R/TP
		R512	0RJ0332D677	33 OHM 1/10 W 5% 1608 R/TP
		R513	0RJ0332D677	33 OHM 1/10 W 5% 1608 R/TP
		R514	0RJ4701D677	4.7K OHM 1/10 W 5% 1608 R/TP
		R515	0RJ4701D677	4.7K OHM 1/10 W 5% 1608 R/TP
		R516	0RJ4701D677	4.7K OHM 1/10 W 5% 1608 R/TP
		R518	0RJ4701D677	4.7K OHM 1/10 W 5% 1608 R/TP
		R519	0RJ1000D677	100 OHM 1/10 W 5% 1608 R/TP
		R520	0RJ4701D677	4.7K OHM 1/10 W 5% 1608 R/TP
		R521	0RJ4701D677	4.7K OHM 1/10 W 5% 1608 R/TP
		R522	0RJ4701D677	4.7K OHM 1/10 W 5% 1608 R/TP
		R523	0RJ4701D677	4.7K OHM 1/10 W 5% 1608 R/TP
		R524	0RJ1000D677	100 OHM 1/10 W 5% 1608 R/TP
		R525	0RJ1000D677	100 OHM 1/10 W 5% 1608 R/TP
		R526	0RJ1000D677	100 OHM 1/10 W 5% 1608 R/TP
		R527	0RJ1000D677	100 OHM 1/10 W 5% 1608 R/TP
		R528	0RJ1000D677	100 OHM 1/10 W 5% 1608 R/TP
		R529	0RJ1000D677	100 OHM 1/10 W 5% 1608 R/TP
		R531	0RJ1000D677	100 OHM 1/10 W 5% 1608 R/TP
		R532	0RJ1000D677	100 OHM 1/10 W 5% 1608 R/TP
		R534	0RJ0000D677	0 OHM 1/10 W 5% 1608 R/TP
		R535	0RJ3301D677	3.3K OHM 1/10 W 5% 1608 R/TP
		R537	0RJ3301D677	3.3K OHM 1/10 W 5% 1608 R/TP
		R541	0RJ1000D677	100 OHM 1/10 W 5% 1608 R/TP
		R542	0RJ1000D677	100 OHM 1/10 W 5% 1608 R/TP
		R543	0RJ4701D677	4.7K OHM 1/10 W 5% 1608 R/TP
		R544	0RJ4701D677	4.7K OHM 1/10 W 5% 1608 R/TP
		R545	0RJ4700D677	470 OHM 1/10 W 5% 1608 R/TP
		R546	0RJ4701D677	4.7K OHM 1/10 W 5% 1608 R/TP
		R547	0RJ4700D677	470 OHM 1/10 W 5% 1608 R/TP
		R548	0RJ0332D677	33 OHM 1/10 W 5% 1608 R/TP
		R549	0RJ0332D677	33 OHM 1/10 W 5% 1608 R/TP
		R555	0RJ1000D677	100 OHM 1/10 W 5% 1608 R/TP
		R556	0RJ4700D677	470 OHM 1/10 W 5% 1608 R/TP
		R557	0RJ1000D677	100 OHM 1/10 W 5% 1608 R/TP
		R560	0RJ1001D677	1K OHM 1/10 W 5% 1608 R/TP
		R561	0RJ4701D677	4.7K OHM 1/10 W 5% 1608 R/TP
		R563	0RJ1000D677	100 OHM 1/10 W 5% 1608 R/TP
		R564	0RJ1000D677	100 OHM 1/10 W 5% 1608 R/TP
		R565	0RJ1000D677	100 OHM 1/10 W 5% 1608 R/TP
		R566	0RJ1002D677	10K OHM 1/10 W 5% 1608 R/TP
		R701	0RJ0752D677	75 OHM 1/10 W 5% 1608 R/TP
		R703	0RJ0752D677	75 OHM 1/10 W 5% 1608 R/TP
		R706	0RJ0752D677	75 OHM 1/10 W 5% 1608 R/TP
		R708	0RJ4700D677	470 OHM 1/10 W 5% 1608 R/TP
		R709	0RJ1001D677	1K OHM 1/10 W 5% 1608 R/TP
		R716	0RJ4701D677	4.7K OHM 1/10 W 5% 1608 R/TP
		R717	0RJ4701D677	4.7K OHM 1/10 W 5% 1608 R/TP
		R720	0RJ0000D677	0 OHM 1/10 W 5% 1608 R/TP
		R722	0RJ1000D677	100 OHM 1/10 W 5% 1608 R/TP
		R723	0RJ0332D677	33 OHM 1/10 W 5% 1608 R/TP
		R724	0RJ0332D677	33 OHM 1/10 W 5% 1608 R/TP
		R726	0RJ1002D677	10K OHM 1/10 W 5% 1608 R/TP
		R727	0RJ1002D677	10K OHM 1/10 W 5% 1608 R/TP
		R737	0RJ0000D677	0 OHM 1/10 W 5% 1608 R/TP

DATE: 2003. 1. 9.				
*S	*AL	LOC. NO.	PART NO.	DESCRIPTION / SPECIFICATION
		R744	0RJ4701D677	4.7K OHM 1/10 W 5% 1608 R/TP
		R745	0RJ4701D677	4.7K OHM 1/10 W 5% 1608 R/TP
		R747	0RJ4701D677	4.7K OHM 1/10 W 5% 1608 R/TP
		R748	0RJ4701D677	4.7K OHM 1/10 W 5% 1608 R/TP
		R769	0RJ0000D677	0 OHM 1/10 W 5% 1608 R/TP
		R772	0RJ1001D677	1K OHM 1/10 W 5% 1608 R/TP
		R773	0RJ4701D677	4.7K OHM 1/10 W 5% 1608 R/TP
		R774	0RJ1001D677	1K OHM 1/10 W 5% 1608 R/TP
		R775	0RJ4701D677	4.7K OHM 1/10 W 5% 1608 R/TP
		R779	0RJ0682D677	68 OHM 1/10 W 5% 1608 R/TP
		R780	0RJ2001D677	2K OHM 1/10 W 5% 1608 R/TP
		R781	0RJ2001D677	2K OHM 1/10 W 5% 1608 R/TP
		R782	0RJ0102D677	10 OHM 1/10 W 5% 1608 R/TP
		R783	0RJ0102D677	10 OHM 1/10 W 5% 1608 R/TP
		R803	0RJ0000D677	0 OHM 1/10 W 5% 1608 R/TP
		R804	0RJ1002D677	10K OHM 1/10 W 5% 1608 R/TP
		R805	0RJ3900D677	390 OHM 1/10 W 5% 1608 R/TP
		R806	0RJ3900D677	390 OHM 1/10 W 5% 1608 R/TP
		R807	0RJ1000D677	100 OHM 1/10 W 5% 1608 R/TP
		R808	0RJ0000D677	0 OHM 1/10 W 5% 1608 R/TP
		R810	0RJ0000D677	0 OHM 1/10 W 5% 1608 R/TP
		R818	0RJ3900D677	390 OHM 1/10 W 5% 1608 R/TP
		R819	0RJ3900D677	390 OHM 1/10 W 5% 1608 R/TP
		R821	0RJ0000D677	0 OHM 1/10 W 5% 1608 R/TP
		R822	0RJ0000D677	0 OHM 1/10 W 5% 1608 R/TP
		R824	0RJ0000D677	0 OHM 1/10 W 5% 1608 R/TP
OTHERs				
		X501	6212AA2004A	HC-49U TXC 12.0MHZ +/- 30 PP
CONTROL BOARD				
		LED1	0DLBE0048AA	BRIGHT LED ELECTRONICS BL-HK
		R1	0RJ4701D677	4.7K OHM 1/10 W 5% 1608 R/TP
		R2	0RJ4701D677	4.7K OHM 1/10 W 5% 1608 R/TP
		R3	0RJ1501D677	1.5K OHM 1/10 W 5% 1608 R/TP
		R4	0RJ1501D677	1.5K OHM 1/10 W 5% 1608 R/TP
		R5	0RJ3301D677	3.3K OHM 1/10 W 5% 1608 R/TP
		R6	0RJ3301D677	3.3K OHM 1/10 W 5% 1608 R/TP
		R7	0RJ9101D677	9.1K OHM 1/10 W 5% 1608 R/TP
		SW1	6600R00004A	JTP1138A6EM JEIL 12VDC 50MA
		SW2	6600R00004A	JTP1138A6EM JEIL 12VDC 50MA
		SW3	6600R00004A	JTP1138A6EM JEIL 12VDC 50MA
		SW4	6600R00004A	JTP1138A6EM JEIL 12VDC 50MA
		SW5	6600R00004A	JTP1138A6EM JEIL 12VDC 50MA
		SW6	6600R00004A	JTP1138A6EM JEIL 12VDC 50MA
		SW7	6600R00004A	JTP1138A6EM JEIL 12VDC 50MA
		ZD1	0DZ560009GB	BZT52C5V6S DIODES R/TP SOD32
		ZD2	0DZ560009GB	BZT52C5V6S DIODES R/TP SOD32
		ZD3	0DZ560009GB	BZT52C5V6S DIODES R/TP SOD32
		ZD4	0DZ560009GB	BZT52C5V6S DIODES R/TP SOD32

PIN CONFIGURATION

MST9111B(ANALOG) MSTAR 128P

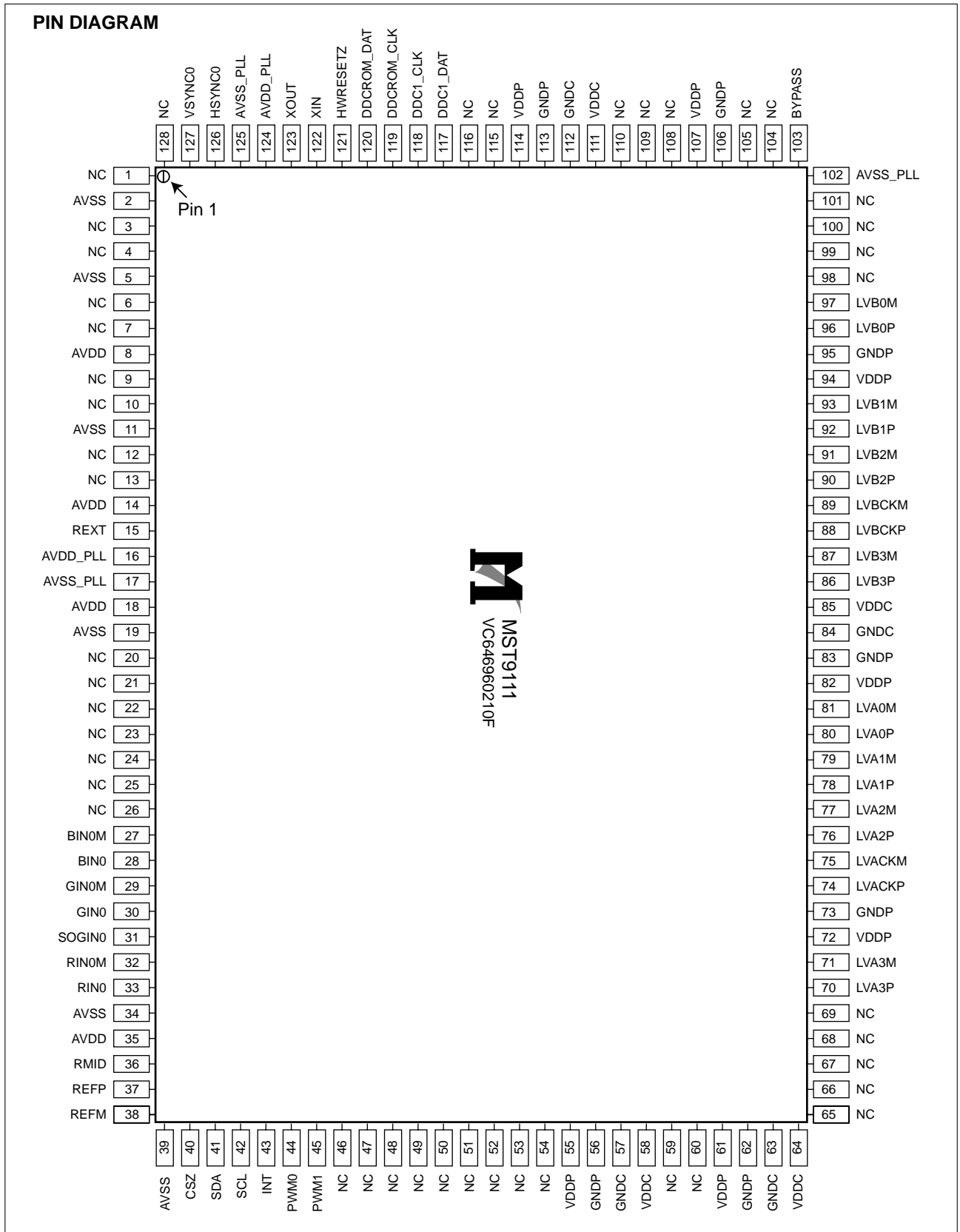

#2 L1510+L1710SM+1910SM MICOM

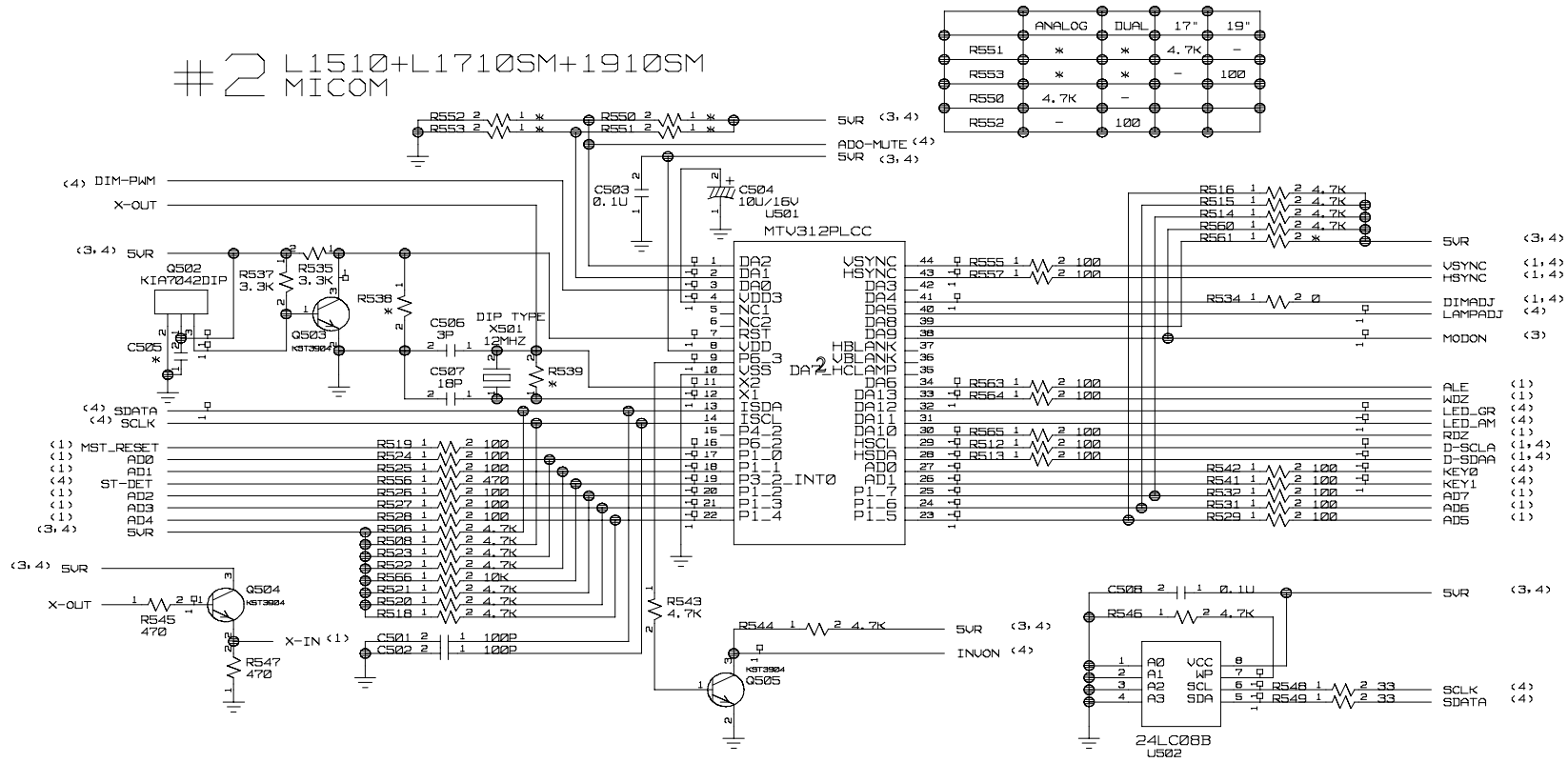

2. MICOM

#3 L1510+1710SM+1910SM POWER

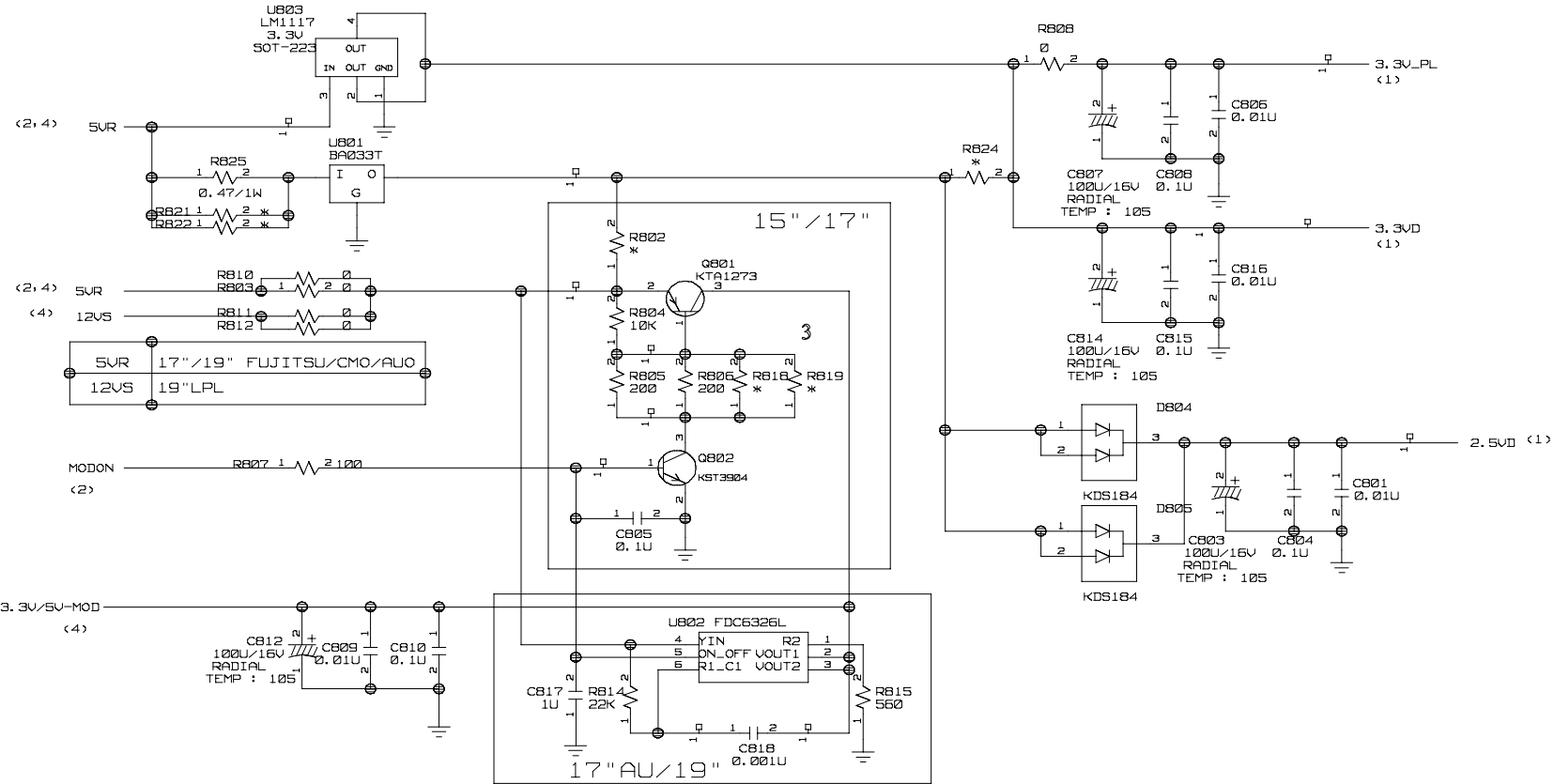

#4 L1510+L1710SM+1910SM CONNECTOR & JACKS

